

Pipe conveyor system

With our range we can offer the ideal solution for you



Your special benefits:

- Flexible conveying routes (vertical/ horizontal)
- Less space requirements
- Easy installation and maintenance
- Any amount of in- and outlets
- Gentle product treatment
- Dustproof conveying
- Functional reliable, long-lasting, low maintenance
- Conveying products: granulate, pellets, flour, ...

Drive unit

standard version made of stainless steel with tensioning device, drive and guide wheel, electromechanical safety switch

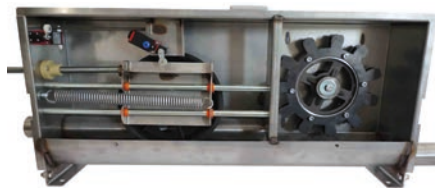

Dosing hopper

made of stainless steel with metering valve and vibrator for adjusting the flow rate, cleaning and inspection opening, for 1- or 2- way conveying systems



Transfer corner 90°

made of glass fiber reinforced plastic (GRP) with sealed ball bearing and stainless steel axle. Also available in 135 ° and 360 ° version.



Conveying pipe with chain

pipe made of galvanized steel or stainless steel with internal conveyor chain made of high-strength steel with plastic attachment



Outlet

with hand or cable operated shut-off valve, connection for downpipe



- Agricultural technology
- Plant construction
- Engineering

Unnerweg 84
D- 49688 Lastrup
Tel.: +49 (0) 4472 940090
Fax.: +49 (0) 4472 940099
E-Mail: kessens@kessens-technik.de

Example for conveying routes

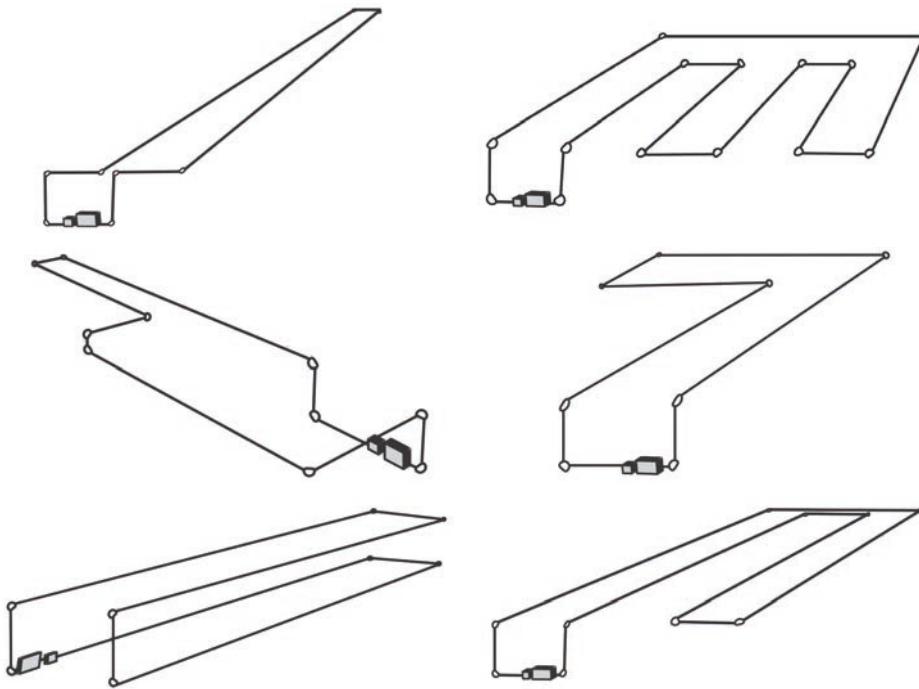

Technical data:

Ø mm	max. length (m)	drive power (kW)	capacity (m ³ /h)
60	400	1,1 - 2,2	3,0
100	280	2,2 - 3,0	8,0



- Agricultural technology
- Plant construction
- Engineering